

April 2009

Electronic Wiper Control

For three Exalto H.D. Wipers



Cat. no. 210312 (12V) • 210324 (24V)

Exalto B.V.

- P.O. Box 40
3370 AA Hardinxveld-Giessendam
The Netherlands
- **T** +31 (0)184 615 800
- **F** +31 (0)184 618 200
- **E** wipers@exalto.com
- **I** www.exaltowipers.com

© Exalto B.V.

Exalto
Quality Marine Equipment

USER MANUAL

Contents

1 General	4
1.1 Functions	4
1.2 Description	5
1.3 Power supply	5
1.4 Technical specifications.....	5
1.5 Default settings	5
1.6 LED indicator bar	6
1.7 Individual wiper buttons	6
1.8 Declaration of conformity	6
2 Installation	7
2.1 Dimensions touch pad	7
2.2 Installation of the touch pad	7
2.3 Dimensions junction box	8
2.4 Installation of the junction box	8
3 Electric connections	9
3.1 General lay out	9
3.2 Wiring codes	9
3.3 Wiper connections	10
3.4 Fuse sizes	11
3.5 Cable sizes	12
4 Operation	12
4.1 ON/OFF switching	12
4.2 Choice of wipers	12
4.3 Continuous mode	12
4.4 Intermittent mode	12
4.5 Wipe/wash program	13
4.6 Synchronised operation	14
4.7 Self parking	14

1 General

1.1 Functions

Brief explanation of buttons and LED's. Please, check chapter 4 for complete operating instructions.

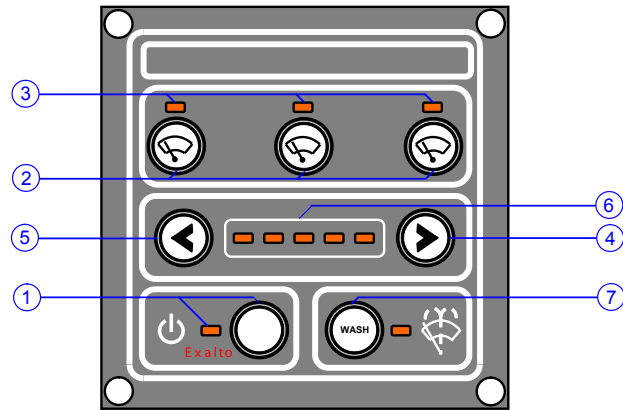

Pos. Function

- 1 Main ON/OFF switch and LED
Turns main power to the system on and off
- 2 Individual wiper ON/OFF buttons
Turns each wiper ON or OFF
- 3 Individual wiper LED
Lights when appropriate wiper is operating
- 4 Intermittent button
Increases the frequency of wiping in the intermittent mode
- 5 Intermittent button
Decreases the frequency of wiping in the intermittent mode
- 6 LED indicator bar
Used to indicate continuous mode or the intermittent setting
- 7 Wipe/wash button
Activates the wipe/wash program

1.2 Description

This electronic wiper control consists of a touch pad with 4 metres (13") connection cable and a separate junction box. The operation is based on a microprocessor and controls up to three wipers. Each wiper can be switched ON and OFF individually, but they can also run together.

This wiper control offers:

- two continuous speed;
- three intermittent speeds;
- self parking;
- wipe/wash program.

This control includes visual indications when it is ON, and for the continuous and intermittent modes.

1.3 Power supply

This wiper control is available in two versions to operate under a power supply of 12V or 24V DC. Check the power supply of the unit supplied, **before** connecting it to the ships electric system.

1.4 Technical specifications

Power supply:	8 – 15V (12V) and 16 – 30V (24V)
Stand-by power consumption:	less than 4W
Protections:	reversed polarity
Working temperature:	-10°C to +60°C
Storage temperature:	-30°C to +70°C
Inputs:	1 – 3 parking signals
Outputs:	1 – 3 wiper contacts pump/solenoid
Max. amperage draw:	12V wipers: 8A 24V wipers: 4A pump/solenoid: 1A

1.5 Default settings

When the wipers are switched ON, an internal test will be carried out. All LED's in the LED indicator bar will lit for a few seconds. All wipers will start in the five second intermittent mode, and LED's A and B will be illuminated.

1.6 LED indicator bar

The LED's on the indicator bar (pos. 6) indicate the following settings:

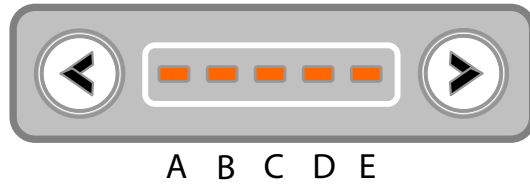

Intermittent modes:

Maximum delay (10 sec): Illuminated LED: A
 Medium delay (5 sec): Illuminated LED's: A + B
 Minimum delay (2,5 sec): Illuminated LED's: A + B + C

Continuous mode:

Low speed: Illuminated LED's: A + B + C + D
 High speed: Illuminated LED's: A + B + C + D + E

1.7 Individual wiper buttons

When pressing the individual wiper buttons (pos. 2), each wiper can be switched ON and OFF individually. Please refer to paragraph 3.3 for the wiper connections.



1.8 Declaration of conformity

This wiper control complies with the European requirements for electromagnetic compatibility, as required from 89/366/EEC, 73/33/EEC and EN60945 directives.

2 Installation

2.1 Dimensions touch pad

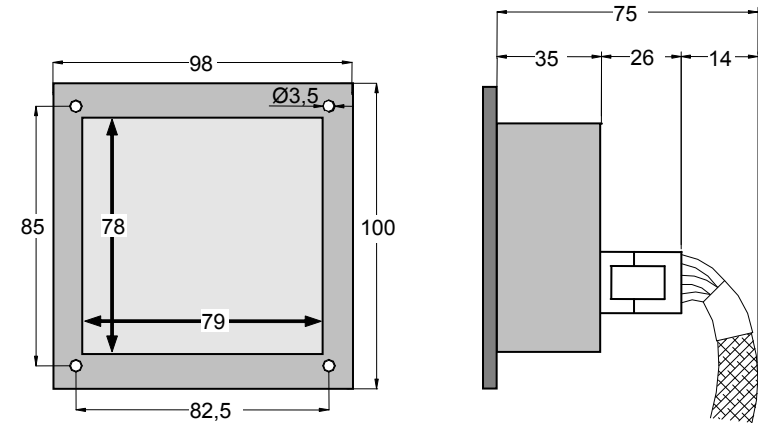

Dimensions in mm

2.2 Installation of touch pad

The touch pad is to be fitted at a location that is within reach of the helmsman, allowing ease of operation. Make sure that sufficient room is available for the cables and the connectors. The required mounting hole for the touch pad is 79 x 80 mm. There should be at least 75 mm (3") space available under the front of the touch pad for the connection cable and plug.

The touch pad has four recessed mounting holes of 3,5 mm in diameter. They allow easy and quickly fitting using stainless steel screws or the bolts and nuts supplied.

2.3 Dimensions junction box

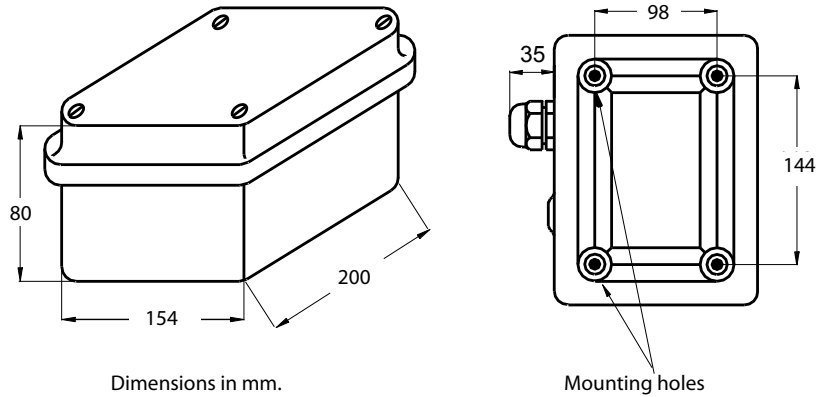

2.4 Installation of junction box

The connection cable of 4 m (13") length allows installation of the junction box at such a distance, that the 'clicking' of the relays will not disturb the helmsman.

Should the junction box need to be installed at a larger distance, extension cables are available in 3 m and 6 m. Maximum distance between the touch pad and the junction box is 10 m.

The junction box must be mounted in a horizontal position and in a vibration free location. The junction box contains relays that will not reset properly if mounted otherwise.

The junction box has four mounting locations (holes not yet drilled). Only two locations can be used, as the other two are blocked by the circuit board. The box needs to be opened for drilling the two holes from the inside. The box can then easily and quickly be fitted using stainless steel screws or bolts and nuts.

3 Electric connections

3.1 General lay out

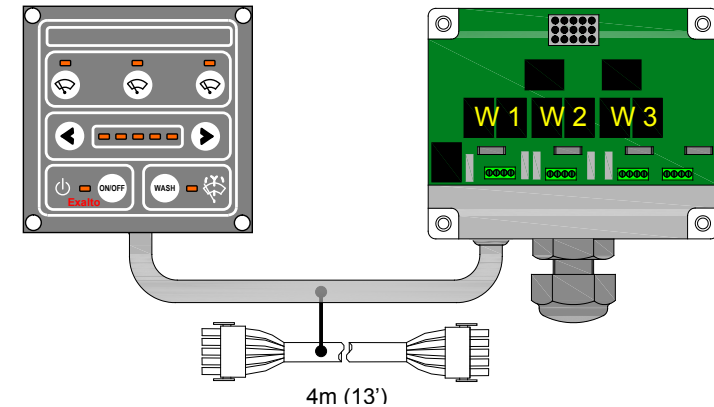

3.2 Wiring codes

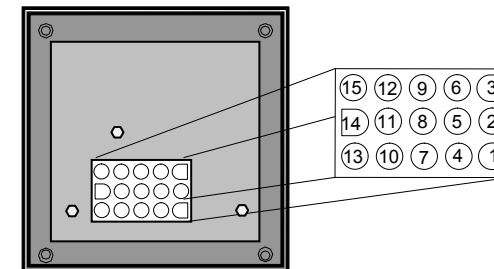

Code and function

- | | |
|-----------------------|---------------------------|
| 1: Battery + | 9: Wiper 3 self-park |
| 2: Not in use | 10: High speed connection |
| 3: Not in use | 11: Wiper 2 relay |
| 4: Negative (-) | 12: Wiper 2 self-park |
| 5: Not in use | 13: Washer pump output |
| 6: Not in use | 14: Wiper 1 relay |
| 7: Dynamic park relay | 15: Wiper 1 self-park |
| 8: Wiper 3 relay | |

3.3 Wiper connections

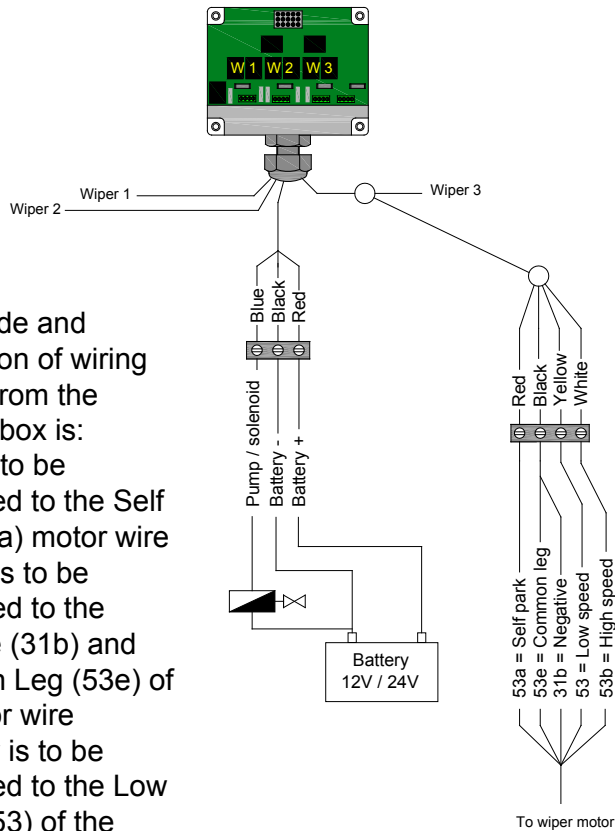

Color code and connection of wiring coming from the junction box is:

- * **Red** is to be connected to the Self Park (53a) motor wire
- * **Black** is to be connected to the Negative (31b) and Common Leg (53e) of the motor wire
- * **Yellow** is to be connected to the Low Speed (53) of the motor wire
- * **White** is to be connected to the High Speed (53b) of the motor wire

Always refer to the users manual as supplied with the Exalto wipers, before connecting Exalto wipers to the control panels!

3.4 Fuse sizes

The power supply line on the circuit board in the junction box has an integrated fuse of 2A. Each wiper outlet has an integrated fuse of 10A for 12V systems and 6A for 24V systems, located in the junction box.

3.5 Cable sizes

Use new cables that are undamaged and of sufficient diameter. This to prevent too much resistance for the required electrical current.

Recommended cable sizes:

Amperage	Max. length	Min. diameter
0.1 – 2.5	10 m (33")	2.5 mm ² (14 gauge)
2.6 – 4.0	10 m (33")	4.0 mm ² (12 gauge)
4.1 – 8.0	10 m (33")	6.0 mm ² (10 gauge)

4 Operation

4.1 ON/OFF switching

With the ON/OFF button (pos. 1) the wipers can be switched on. When pressing this button once, an internal test is carried out. The wipers will start in the default setting and the LED's above the individual wiper buttons (pos. 3) will illuminate. The LED next to the ON/OFF button (pos. 1) will stay illuminated as long as the panel is ON. When this button is pressed again, all wipers will park and stop.

4.2 Choice of wipers

When pressing one of the wiper buttons on pos. 2 each wiper can be switched ON and OFF individually. The LED's above these buttons (pos. 3) indicate which wipers are activated. Switching ON a wiper when the others are already operating may cause a short delay of the other wipers. This is to synchronise the operation

4.3 Continuous mode

To activate the continuous mode in low speed, press the button on pos. 4 until LED's A, B, C and D on the LED indicator bar (pos. 6) are illuminated. The wipers will run synchronized. Press once more on the button on pos. 4 and the continuous high speed mode is activated. All five LED's in the LED bar (pos. 6) will be illuminated.

4.4 Intermittent mode

To activate the intermittent mode, press the button on pos. 5 until the required delay setting is reached. The wipers will run synchronised in all intermittent settings.

LED's illuminated	Delay	Speed mode
1 LED: A	10 sec.	Intermittent
2 LED's: A + B	5 sec.	Intermittent
3 LED's: A + B + C	2,5 sec.	Intermittent
4 LED's: A + B + C +D	low speed	Continuous
5 LED's: A + B + C +D	high speed	Continuous

4.5 Wipe/wash program

This wiper control has a built in 'smart' wipe/wash program which can be activated by pressing the wipe/wash button (pos. 7). When shortly pressing this button, the standard program will be started:

- The pump or solenoid will be activated allowing water to be sprayed onto the screen.
- After three seconds, all wipers will start to run in the low speed mode for a period of four seconds. Water will still be sprayed.
- After four second, the water supply will be stopped and the wipers will run for another three seconds.
- After the program has been completed, the wipers will go back to the setting that was previously used.

Besides the standard wipe/wash program as described before, you can also choose a personalised program. The available programs are visualised here:

Standard program: press WASH button (pos. 7) once.

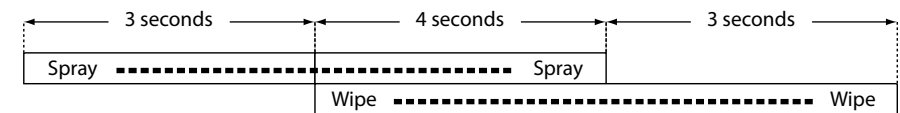

Personalised program: keep WASH button (pos. 7) pressed.

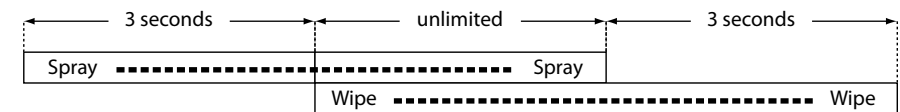

As long as the wipe/wash program is active, the LED next to the WASH button will be illuminated. After the wash program has ended, all active wipers will go back to the setting that was previously used.

As a standard, the wipers are included in the wash program. However, a wiper can be excluded from the program as follows:

- Press the button on pos. 4 or pos. 5 until LED's A, B, C, D and E blink.
- Press the button of the wiper that needs to be excluded and the respective LED will go off.
- Press ON/OFF button (pos. 1) to store the new situation in the memory.

To undo, follow the same steps and the respective LED will illuminate again.

4.6 Synchronised operation

All wipers will run synchronised in each speed mode.

4.7 Self parking

When pressing the ON/OFF button (pos. 1) the wipers will go to the corner of the screen and park, providing the wiper motors are equipped with a self-park function.